

**UPWARDOR**® T.M.  
CORP.



# AL976

# Aluminum Door



# BUILT TO EXCEED

# Upwardor® Moves Ahead...



Manufactured since 1976, **Upwardor®'s AL976 Aluminum** door offers a variety of exclusive options for applications that require superior strength, maximum visibility and unlimited light transmission. Its' revolutionary construction allows customized designs for openings up to 24 feet wide.

All aluminum members are manufactured from extruded **6063-T6** aluminum alloy in a standard clear anodized finish. A diverse range of custom anodized colours and paint finishes are also available to enhance its appearance. Since its introduction, the **AL976** has proven itself in a wide variety of applications such as Service Stations, Lube Shops, Fire Halls, Bus Terminals, Restaurant fronts and other such industrial/commercial facilities. Built to last, the **AL976** incorporates a number of features to ensure long term durability and performance such as:

- Horizontal members with integral strut bars.
- Tongue and groove section joints with weather seal.
- Horizontal members with face dimensions to incorporate half and full hinges.
- "Removable" snap on PVC mouldings and soft vinyl glazing bead.
- Glazing options: tempered glass, thermopane, Polycarbonate, acrylic or lexan.
- Solid bottom options: stucco panel, anti-dent panel or **Thermallex®** panel.

These are but a few of the many attributes that takes the **AL976** a step beyond other aluminum framed doors. Renowned for its quality and durability, **Upwardor®'s AL976 Aluminum** door is another exquisite example of the pride and knowledge we put into every product we build.

# Proven Superior Quality Through Continuous Design & Innovations

With over 20 years manufacturing experience, **Upwardor® Corporation** is a trade mark of excellence in design and quality. Due to our continuous innovations, **Upwardor®** products are consistently rated above and beyond industry standards. Our firm dedication to move forward has made the **AL976** aluminum door the premier choice of the industry.

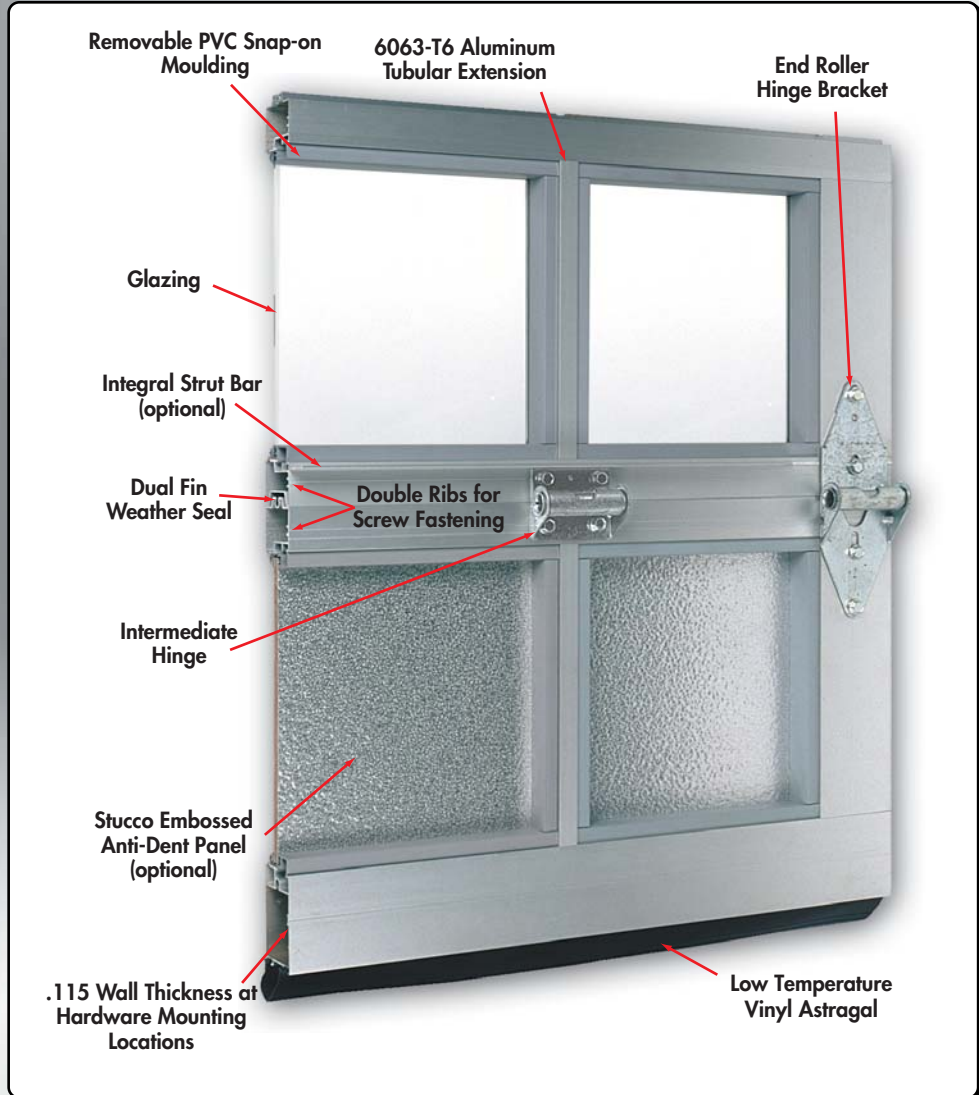
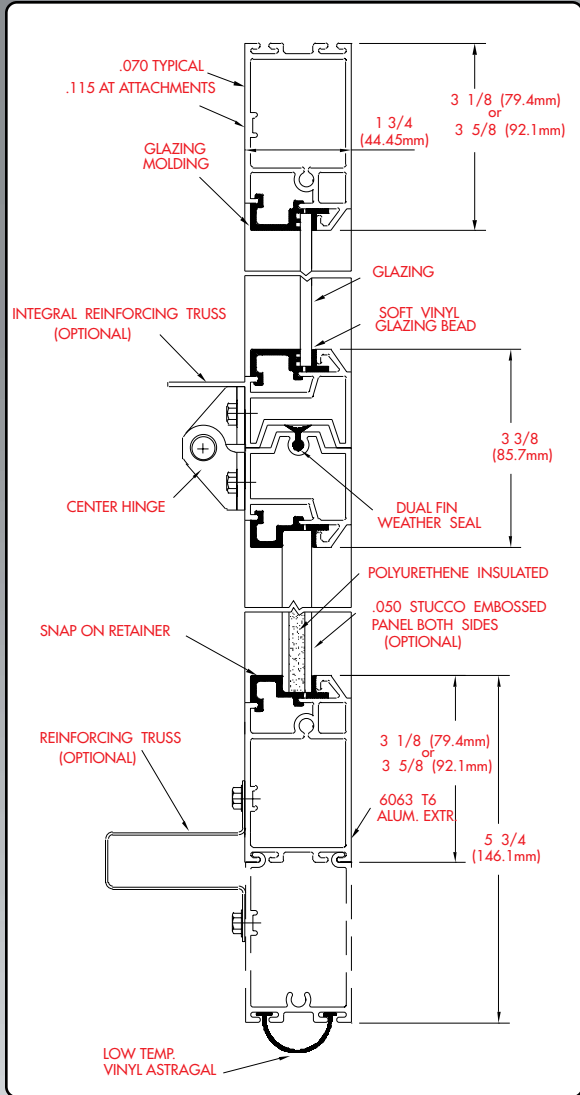

Section Schedule		Panel Schedule	
Door Height	Sections High	Door Width	Panels Wide
8'-6" or less	4	8'-2" or less	2
8'-7" to 10'-6"	5	8'-3" to 11'-2"	3
10'-7" to 12'-6"	6	11'-3" to 14'-2"	4
12'-7" to 15'-0"	7	14'-3" to 17'-2"	5
15'-1" to 17'-0"	8	17'-3" to 20'-2"	6
17'-1" to 19'-6"	9		
19'-7" to 22'-6"	10		

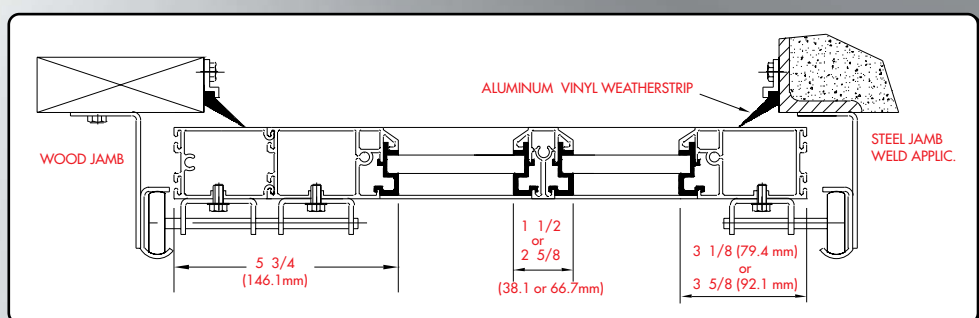

# Door Specifications:

# AL976 Aluminum

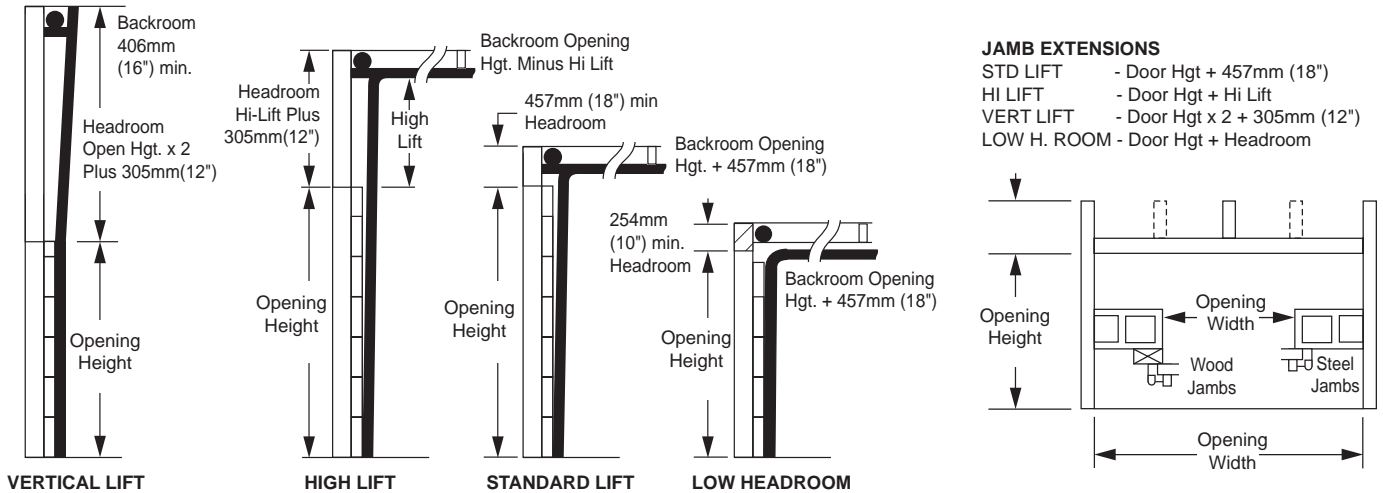

**Sectional Doors:** Doors shall be of **AL976 Aluminum** as manufactured by **Upwardor® Corporation**, 1094 Westport Cres., Mississauga, Ontario, L5T 1G1, Canada.

**Door Sections:** **AL976 Aluminum** sections shall be 45mm (1-3/4" thick and extruded from 6063-T6 aluminum alloy in a standard clear anodized finish. All aluminum members shall be of tubular extrusions with wall thickness of .070 and .115 thickness at hardware mounting locations. Stiles and end rails to be double tenon and assembled with self threaded bolts. Top and bottom rail shall be minimum of 80mm (3-1/8") or 92mm (3-5/8"), for doors 16'-0" and wider bottom rail shall be 146mm (5-1/2") reinforced with galvanized steel hat strut bar. Meeting rails shall be 86mm (3-3/8") high incorporating full width integral strut bar for doors 16' - 0" wider. Centre stiles shall be 38mm (1-1/2") for centre half hinge and 42mm (2-5/8") for centre full hinge. End stiles to be 80mm (3-1/8") or 92mm (3-5/8") for single end hinge and 146mm (5-1/2") wide for double end hinges. Bottom section to be **Thermalex® 2000** stucco embossed insulated panel (optional), single .050 stucco aluminum panel or 10mm (3/8") anti-dent double aluminum stucco panel. Sections shall have dual fin weather seal between joints and exterior perimeter weather strip of aluminum extrusion with low temperature vinyl.

**Glazing:** Glazing materials to be single glass 3mm clear, .050 stucco aluminum panel or 13mm (1/2") thermopane sealed units up to 168 sq. ft. set in a continuous soft vinyl bead held in place with a removable type P.V.C. snap on moulding.

**Tracks:** Shall be of 51mm (2") minimum, 14 gauge (2mm), or 76mm (3") minimum, 12 gauge (2.7mm). All vertical tracks shall be bolted and assembled to a continuous 51mm (2") x 102mm (4") vertical angle, minimum 14 gauge (2mm), or to jamb brackets, 11 gauge (3mm), and shall be totally adjustable. Horizontal tracks shall have a maximum radius of 381mm (15") with a continuous 12 gauge (2.7mm) angle, 38mm (1-1/2") x 51mm (2"), welded or bolted to the horizontal tracks.

**Hinges:** Roller carriers shall be minimum 13 gauge (2.4mm) galvanized steel to suit door width. (16'-0" wide doors and over; specify double end hinges, along with hat strut bar reinforcement). Rollers shall be of 15mm (2") or 76mm (3") diameter, 10 ball bearing with hardened raceway and cold rolled 1mm (7/16") x 114mm (4-1/2") stem. Long stem, 203mm (8"), rollers supplied with double end hinges.

**Torsion Springs:** Shall be oil tempered with 10,000 standard cyclage (specify higher cyclage if required to maximum 100,000 cycles) fitted on a continuous 25mm (1") hollow, 14 gauge (2mm) tube shaft, or on a 25mm (1") or 32mm (1-1/4") cold rolled solid shaft, keyed and mounted on ball bearings, supported by heavy gauge gusset plates, (counter weight system available on request).

**Cable Drums:** Shall suit the type of lift required and be able to withstand maximum cycle requirements. Cables shall be of galvanized aircraft grad, 7x19 construction, designed to suit door weight at a safety factor of 8 to 1.

**Note:** When specifying Chain Hoist or Jack Shaft Electrical operator on standard lift doors, specify solid shaft, spreader bars, and pusher springs.

**Work By Others:** All framing work, spring pads, frame extensions, caulking and electrical wiring shall be under other divisions.

**Options:** **Upwardor®** offers a full range of hardware lift type options, door operating devices, and safety features. Please consult factory for specifications.



**Dealers Nation-wide:**  
**Call us for the Dealer nearest you.**

8025 Lawson Road  
 Milton, Ontario • Canada • L9T 5C4  
 • Phone: 905-876-3667 • Fax: 905-876-3533  
 • Call Toll-Free: 1-800-667-3367  
 • e-mail: [upwardor@upwardor.com](mailto:upwardor@upwardor.com)  
 Visit our Web Site: [www.upwardor.com](http://www.upwardor.com)

Distributed by: